

# Technical Data

## 2800 Series

## 2806C-E18TAG1A

Diesel Engine - Electropak

### Basic technical data

Number of cylinders .....	6
Cylinder arrangement .....	Vertical, in line
Cycle .....	4 stroke, compression ignition
Induction system .....	Turbocharged, air to air charge cooling
Compression ratio .....	14.5:1 Nominal
Bore .....	145 mm
Stroke .....	183 mm
Cubic capacity .....	18,13 litres
Direction of rotation .....	Anti-clockwise viewed on flywheel
Firing order .....	1, 5, 3, 6, 2, 4
Cylinder 1 .....	furthest from flywheel

### Total weight Electropak

-dry .....	2050 kg
-wet .....	2158 kg

### Overall dimensions

-height .....	1807,5 mm
-length .....	2545,0 mm
-width .....	1536,0 mm

### Moment of inertia (mk<sup>2</sup>)

-flywheel @ 1500 rev/min .....	4,74 kgm <sup>2</sup>
-engine @ 1500 rev/min .....	2,31 kgm
-flywheel @ 1800 rev/min .....	4,74 kgm <sup>2</sup>
-engine @ 1800 rev/min .....	2,70 kgm

### Performance

**Note:** All data based on operation to ISO 3046/1, BS5514 and DIN 6271 standard reference conditions.

### Cyclic irregularity

for engine/flywheel maximum	
1500 rev/min .....	0,0192
1800 rev/min .....	0,01163

### Ratings

Steady state speed stability at constant load .....

Electrical ratings are based on average alternator efficiency and are for guidance only (0.8 power factor being used).

### Operating point

Engine speed .....	1500/1800 rev/min
Cooling water exit temp. ....	88 - 103 °C

### Fuel data

To conform to .....

### Noise

Estimated sound pressure levels:

1500 rev/min .....	105,3 dB(A)
1800 rev/min .....	108,0 dB(A)

**Note:** Noise level represents highest recorded at 1500 and 1800 rev/min respectively

### Test conditions

Air temperature .....	25 °C
Barometric pressure .....	100 kPa
Relative humidity .....	30%
Air inlet restriction at maximum power (nominal) .....	2,5 kPa
Exhaust back pressure at maximum power (nominal) .....	6,0 kPa
Fuel temperature (inlet pump) .....	40 °C

**Note:** If the engine is to operate in ambient conditions other than those of the test conditions, suitable adjustments must be made for these changes

## General installation

Designation	Units	Type of operation and application			
		Prime	Standby	Prime	Standby
		50 Hz @ 1500 rev/min		60 Hz @ 1800 rev/min	
Gross engine power	kWb	532,0	583,8	567,7	623,0
Fan, battery and alternator power	kWm	9,0		15,0	
Restriction losses	kWm	9,0	9,8	9,5	10,3
Nett engine power	kWm	514	565	543	598
BMEP gross	kPa	2347	2576	2087	2290
Combustion air flow	m <sup>3</sup> /min	40	41	45	47
Exhaust gas temperature (after turbo)	°C	550	565	487	507
Exhaust gas flow	m <sup>3</sup> /min	110	115	114	122
Boost pressure ratio	-	3,03	3,10	3,10	3,30
Overall thermal efficiency (nett)	%	40	42	42	42
Friction power and pumping losses	kWm	20		34	
Mean piston speed	m/s	9		11	
Engine coolant flow	l/s	6,1		7,2	
Cooling fan airflow	m <sup>3</sup> /min	702		852	
Typical gen set electrical output 0.8 pf	kWe	473	520	500	550
	kVa	591	650	625	687
Assumed alternator efficiency	%	92		92	

**Note:** Quoted gross engine power includes an allowance of 1-5% for installation variances

## Rating definitions

### Prime power

Variable load. Unlimited hours usage with an average load factor of 80% of the published Prime Power rating over each 24 hour period. A 10% overload is available for 1 hour in every 12 hours operation

### Standby power

Variable load. Limited to 500 hours annual usage up to 300 hours of which may be continuous running. No overload is permitted.

### Emissions statement

Certified against the requirements of EU2007 legislation for non-road mobile machinery, powered by constant speed engines (EU97/68/ EC Stage II). These engines also comply with the 1/2 TA Luft (1986) NOx limits of 2000 mg/nm<sup>3</sup>

## Energy balance

Designation	Units	Prime	Standby	Prime	Standby
		50 Hz @ 1500 rev/min		60 Hz @ 1800 rev/min	
Energy in fuel	kWt	1328	1398	1354	1490
Energy in power (gross)	kWb	532	584	568	623
Energy to Fan and restriction losses	kWm	18,0	18,8	24,5	25,3
Energy to coolant and lubricating oil	kWt	150	160	162	182
Energy to exhaust	kWt	480	491	457	498
Energy to charge cooler	kWt	118	121	125	138
Energy to radiation	kWt	48	42	43	49

## Cooling system

Recommended coolant: 50% clean water with 50% Perkins ELC. Where there is no likelihood of ambient temperature below 10 °C, clean 'soft' water may be used, treated with 1% by volume of Perkins inhibitor in the cooling system. The inhibitor is available from Perkins.

Nominal jacket water pressure in crankcase . . . . . 280 kPa  
 Maximum top tank temperature (standby) . . . . . 103 °C  
 Thermostat operating range... . . . . . 88 - 98 °C  
 Ambient cooling clearance maximum duct allowance and resultant minimum airflow (standby power). Based on air temperature at fan 10 °C above ambient

Duct Allowance kPa	Ambient Clearance °C	Min Airflow m³/min	Ambient Clearance °C	Min Airflow m³/min
	1500 rev/min		1800 rev/min	
0	49	702	54	852
0,13	46	660	52	804
0,19	42	630	52	792
0,25	37	606	51	762

### Radiator

-face area... . . . . . 1,75 m²  
 Rows and material . . . . . 2 Aluminium  
 Fins per inch . . . . . 15

### Width and height of matrix

-height . . . . . 1260 mm  
 -width . . . . . 1390 mm  
 Total coolant capacity (radiator and engine).. . . . . 61 litres  
 Pressure cap setting . . . . . 70 kPa

### Charge cooler, integral with radiator

Face area... . . . . . 1,623 m²  
 Rows and material . . . . . 1 Aluminium  
 Fins per inch . . . . . 14

### Width and height of matrix

-height . . . . . 1390 mm  
 -width . . . . . 1180 mm

### Coolant pump

Speed. . . . . 1,08 x e rev/min  
 Method of drive . . . . . Gear

### Fan

Type . . . . . Pusher  
 Drive ratio... . . . . 0,8:1  
 Diameter . . . . . 965 mm  
 Number of blades... . . . . 9  
 Material . . . . . Plastic

## Recommended SAE viscosity

A single or multigrade oil must be used which conforms to API CG4 or APEA E5.

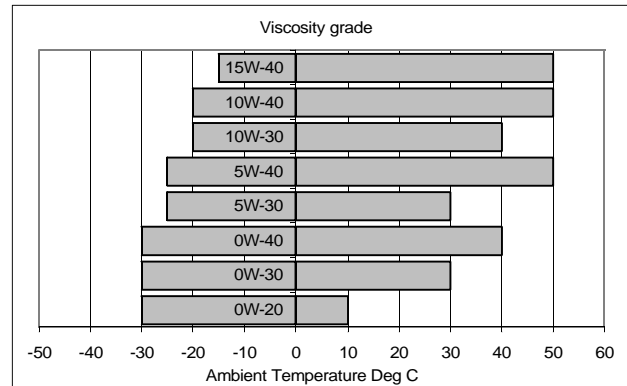

## Lubrication system

### Lubricating oil capacity

Total system . . . . . 62,0 litres  
 Sump maximum . . . . . 53,0 litres  
 Sump minimum . . . . . 45,0 litres

### Lubricating oil temperature (sump)

Normal. . . . . 95 °C  
 Maximum. . . . . 113 °C

### Lubricating oil pressure

At rated speed . . . . . 420 kPa  
 Minimum... . . . . 200 kPa  
 Oil relief valve opens... . . . . 610 kPa  
 Oil filter spacing... . . . . 30 µm  
 Sump drain plug tapping size... . . . . 1 in NTPF  
 Oil pump speed and method of drive . . . 1,16 x engine speed, gear  
 Oil pump flow 1500/1800 rev/min . . . . . 2,90 / 3,48 litres/sec  
 Oil consumption as a percentage of full load fuel  
 -less than. . . . . 0,1%

### Normal operating angles

Front and rear. . . . . 7° maximum  
 side tilt . . . . . 7° maximum

## Electrical system

Type . . . . . Insulated return  
 Alternator output... . . . . 24 volts / 70 amps  
 Starter motor power. . . . . 9 kW  
 Number of teeth on flywheel . . . . . 136  
 Number of teeth on starter motor . . . . . 11  
 Minimum cranking speed . . . . . 115 rev/min  
 Pull-in current of starter motor solenoid . . . . . 49 amps  
 Hold-in current of starter motor solenoid . . . . . 6 amps

### Engine management system

Full electronic engine management system controlling:

- Speed governing
- Air / Fuel ratio
- Start sequence
- Engine Protection and diagnostics.

## Starting requirements

Temperature range	
Down to -10 °C (14 °F)	Oil: 15W / 40 API CG4 Starter: 24 Volt Battery: 2 x 12V 128 Ah Max breakaway current: 1400 Amps Cranking Current: 700 Amps Aids: Not required
Down to -25 °C (-13 °F)	Oil: 0W / 30 API CG4 Starter: 24 volt Battery: 2 x 12V 128 Ah Max breakaway current: 1400 Amps Cranking Current: 600 Amps Aids: Block heater to 45 °C

### Notes:

- The battery capacity is defined by the 20 hour rate at 0 °C
- The oil specification should be for the minimum ambient temperature as the oil will not be warmed by the immersion heater
- The breakaway current is dependant on the battery capacity available. Cables should be capable of handling the transient current which may be up to double the steady cranking current.

## Induction system

Air intake restriction: ... 3,7 kPa  
 Maximum restriction (dirty filter) ... 6,35 kPa  
 Air filter type:  
 -1500 rev/min ... Paper element 457 mm Diameter  
 -1800 rev/min ... Paper element 533 mm Diameter

## Exhaust system

Exhaust outlet size (internal) ... 202 mm  
 Maximum exhaust back pressure for total system ... 6,9 kPa  
 For recommended pipe sizes, see installation manual.

## Fuel system

Type of injection system ... MEUI  
 Fuel injector pressure ... 200 MPa

### Fuel lift pump

Delivery per hour at 1500/1800 rev/min ... 413 / 457 litres/hour  
 Fuel delivery pump  
 -delivery pressure.. 600 kPa  
 -maximum suction head ... 3 m  
 -maximum pressure head ... 4 m

### Governor

Electronic governor speed to conform to ... ISO 8528 - Class G3  
 Mechanical governor speed to conform to ... ISO 8528 - Class G2

### Fuel filtration level

Primary ... 10 µm  
 Secondary ... 2 µm

## Typical fuel consumption

Fuel consumption calculated on engine nett rated powers				
Rating	g/kWh		Litres/hr.	
	1500	1800	1500	1800
Standby	205	207	134	144
Prime + 10%	205	207	135	144
Prime	216	206	129	130
At 75% of Prime	214	212	96	100
At 50% of Prime	212	226	63	71

**Note:** Assumed fuel density 0,862 kg/l.

## Engine mounting

Maximum bending moment  
 -at rear face of the engine crankcase ... 1356 Nm  
 Position of centre of gravity (bare dry engine):  
 -forward of the rear face of the engine crankcase... 550 mm  
 -above crankshaft centre line ... 250 mm  
 Weight of engine and cooling system:  
 -engine (bare dry) ... 1832 kg  
 -radiator (dry) ... 200 kg

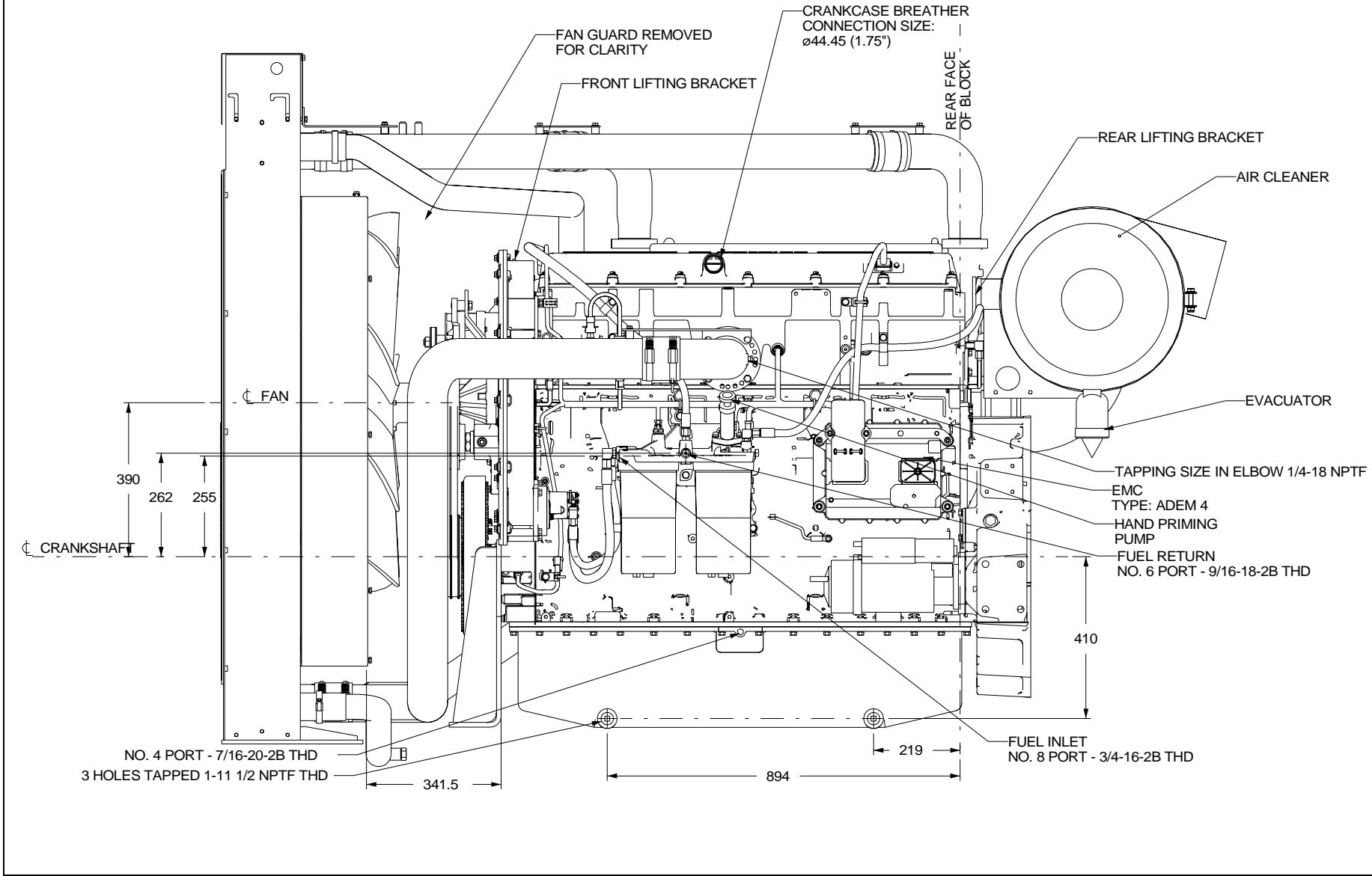

2806C-E18TAG1A - front view

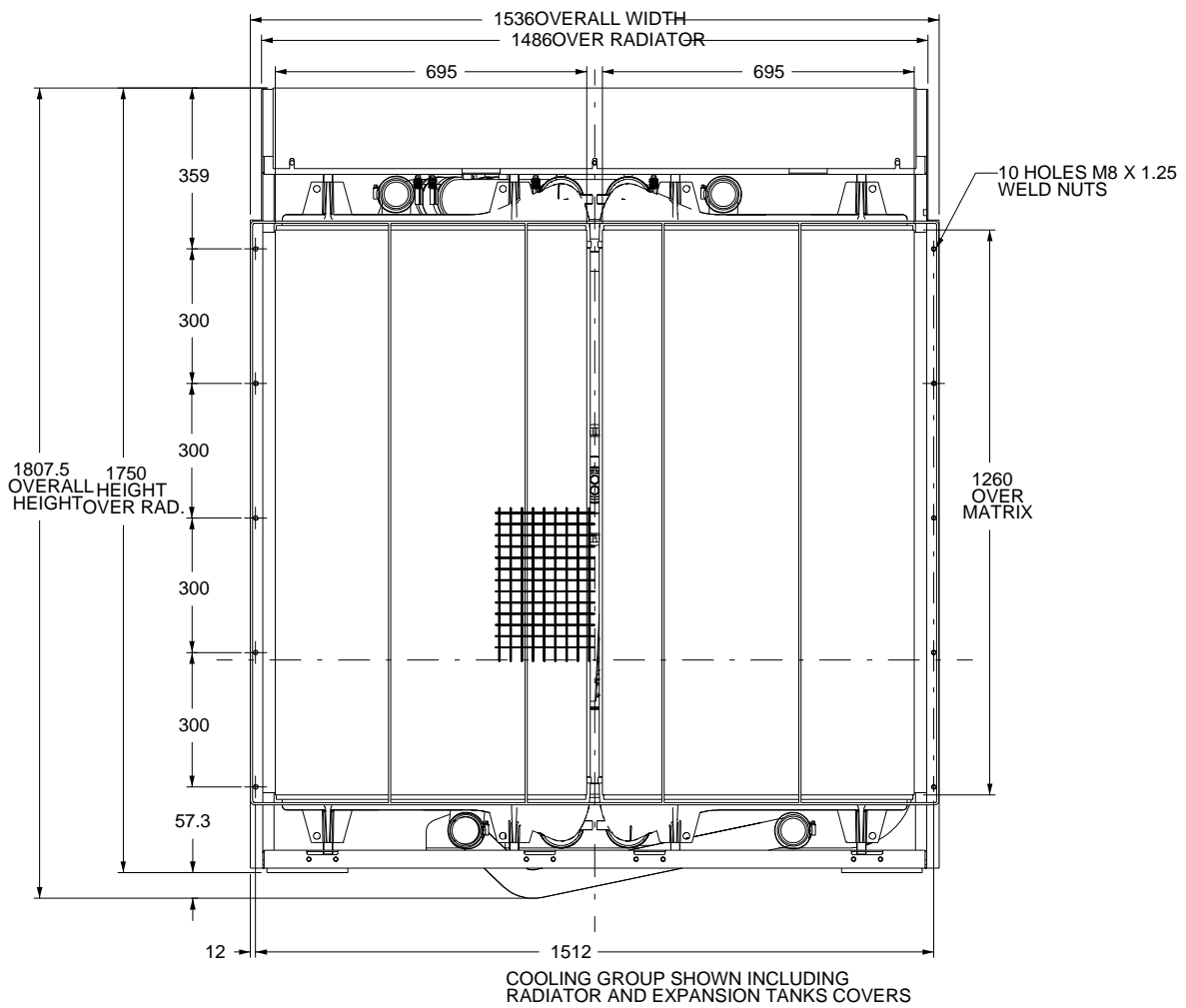

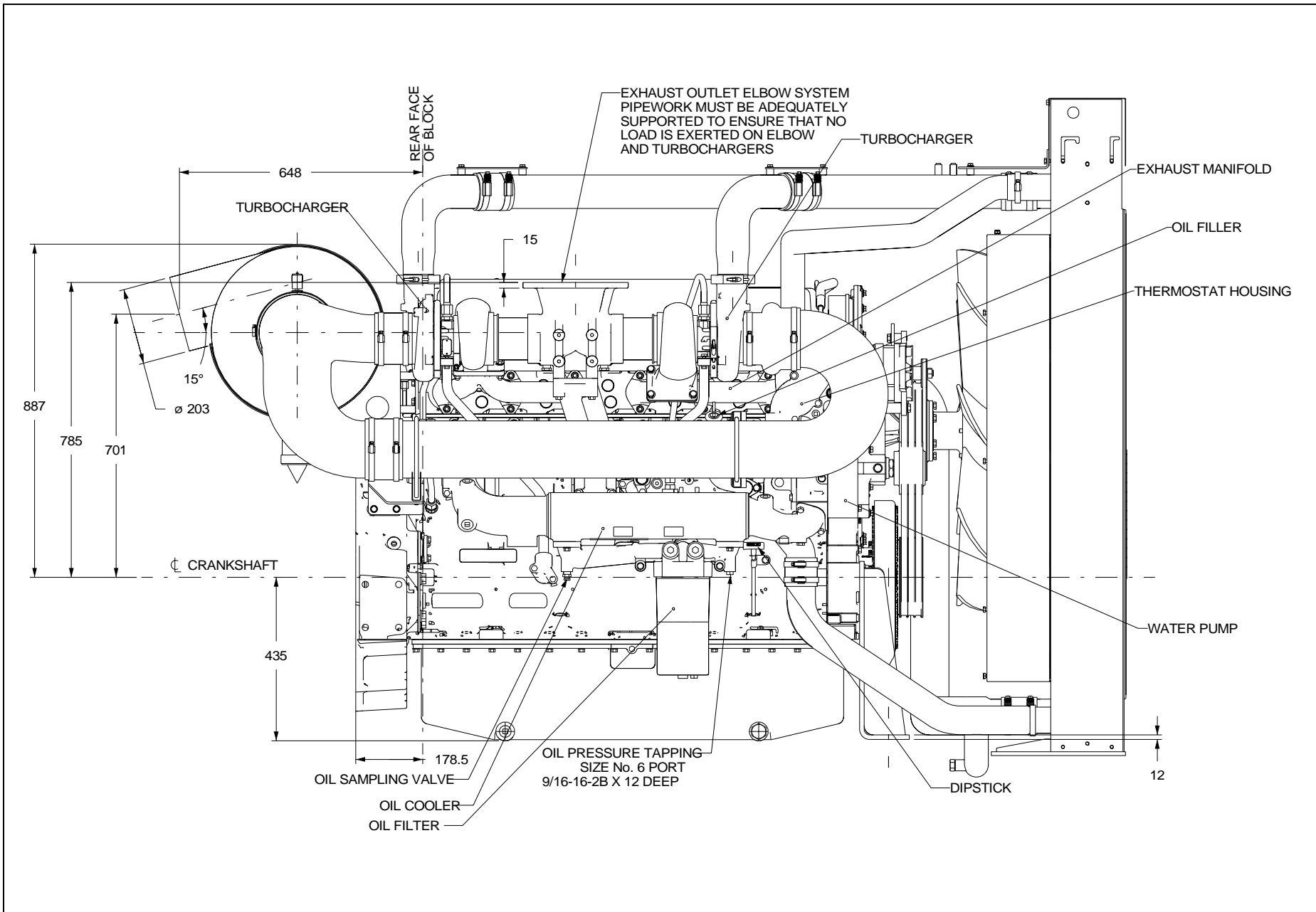

2806C-E18TAG1A - rear view

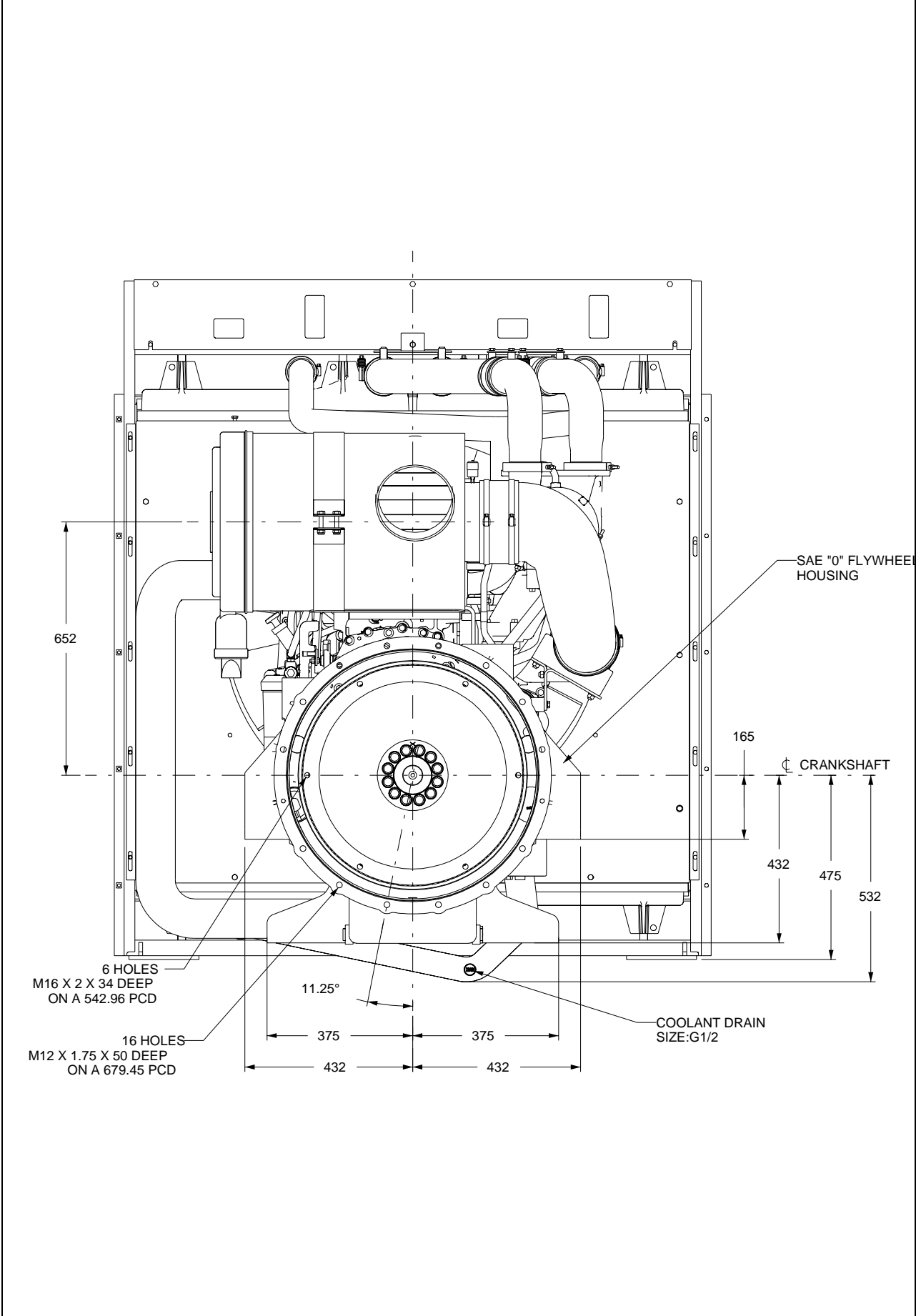



## Typical load acceptance

Prime %	1500 rev/min				1800 rev/min			
	Load on		Load off		Load on		Load off	
	Transient % speed change	Speed recovery time (sec)	Transient % speed change	Speed recovery time (sec)	Transient % speed change	Speed recovery time (sec)	Transient % speed change	Speed recovery time (sec)
20	1,8	1,2	1,5	1,0	1,3	1,0	1,1	1,0
40	3,6	1,4	3,1	1,2	2,6	1,5	2,2	1,5
60	6,4	2,2	4,8	1,6	4,4	2,1	3,3	1,8
70	9,8	2,8	5,9	1,8	6,1	2,7	4,2	1,8
80	13,5	2,9	6,5	1,9	8,1	3,0	4,8	1,8
100	22,1	3,7	8,3	2,2	12,7	3,5	5,9	2,0

The above figures were obtained under test conditions as follows:

Engine block temperature: .....45 °C

Minimum ambient temperature .....10 °C

Governing mode ..... Isochronous

Alternator inertia ..... 10,4 kgm<sup>2</sup>

Under frequency roll off (UFRO) point set to ..... 1 Hz below rated frequency

UFRO rate set to ..... 2 % voltage / 1% frequency

LAM on / off..... off

All tests were conducted using an engine installed and serviced to Perkins Engines Company Limited recommendations.

Applied load is a percentage of generator electrical output using alternator efficiencies as published in the general installation section of this data sheet.

**The information given on Technical Data Sheets is for standard ratings only. For ratings other than shown contact Perkins Engines Company Limited, Stafford.**

**The information given in this document is for guidance only**

**Notes**



Perkins Engines Company Limited  
Peterborough PE1 5NA United Kingdom  
Telephone +44 (0) 1733 583000  
Fax +44 (0) 1733 582240  
[www.perkins.com](http://www.perkins.com)

All information in the document is substantially correct at the time of printing but may be subsequently altered by the company.

Distributed by



Distributed by